

1.F.S-2009

Sl. No.

1022

B-JGT-J-DFA

CIVIL ENGINEERING

Paper I

Time Allowed : Three Hours

Maximum Marks : 200

INSTRUCTIONS

Candidates should attempt questions 1 and 5 which are compulsory, and any THREE of the remaining questions selecting at least ONE question from each Section.

Assume any missing data suitably and indicate the same clearly in your answer.

Standard notations are given in the questions and these notations have their usual meanings, unless otherwise indicated.

The number of marks carried by each question is indicated at the end of the question.

Answers must be written in ENGLISH only.

Section - A

1. Answer any *four* of the following : $10 \times 4 = 40$

- (a) (i) Discuss $m = 2J - 3$ with reference to perfect frame, redundant frame and deficient frame. 6

(Contd.)

(ii)

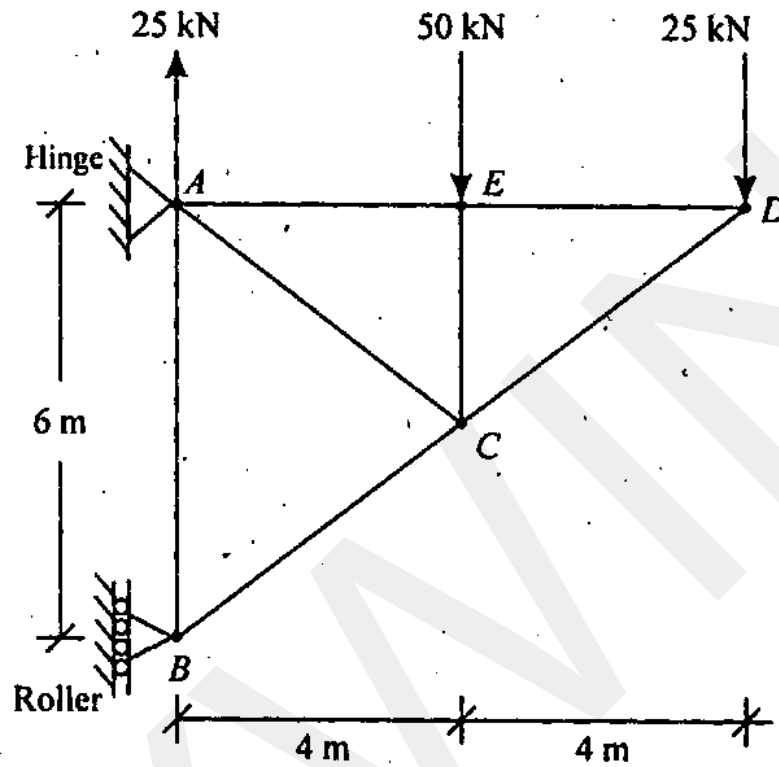

For the truss as shown above evaluate the reactions at A and B. 4

(b)

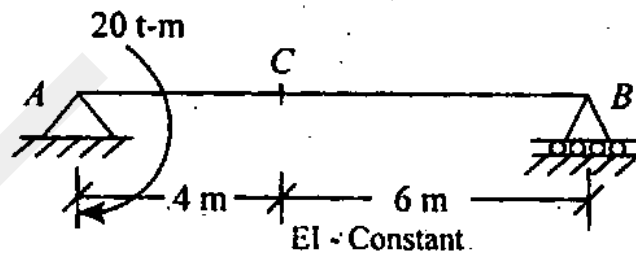

Calculate the slope and deflection at C in the Beam AB as shown above. Find also the point of maximum deflection and its magnitude. 10

(c) (i)

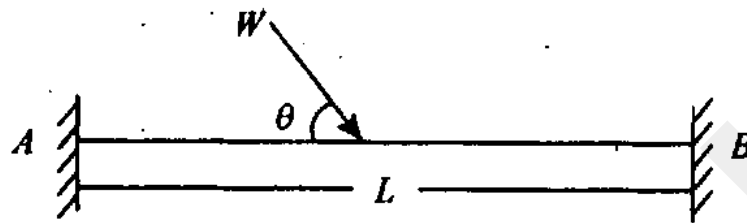

i) Fixed Beam

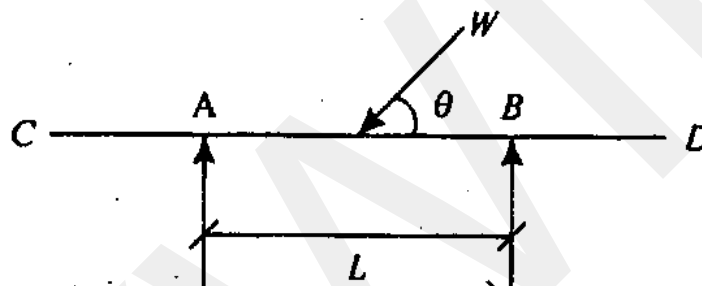

ii) Overhang Beam

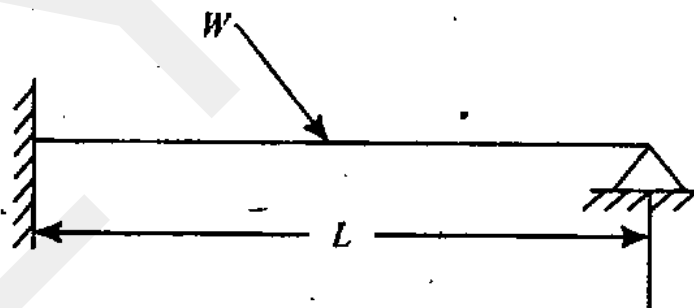

iii) Propped Cantilever Beam

State the conditions of static equilibrium for the given beams as shown above. State whether they are statically determinate or indeterminate. 5

(ii)

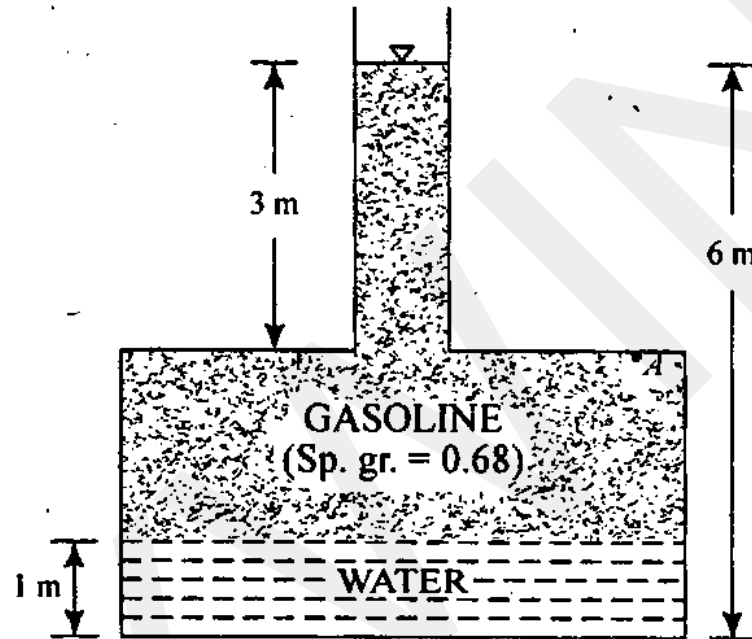

Water seeps near the bottom of a buried Gasoline (sp. gr. = 0.68) storage tank and rises to a depth of 1 m as shown in the above figure. If the free surface of Gasoline is at 6 m above the tank bottom, find the gauge pressure at a point A, inside the tank's upper-surface and that at the Gasoline-water interface. What will be the pressure at the bottom of tank in metres of water? 5

(d)

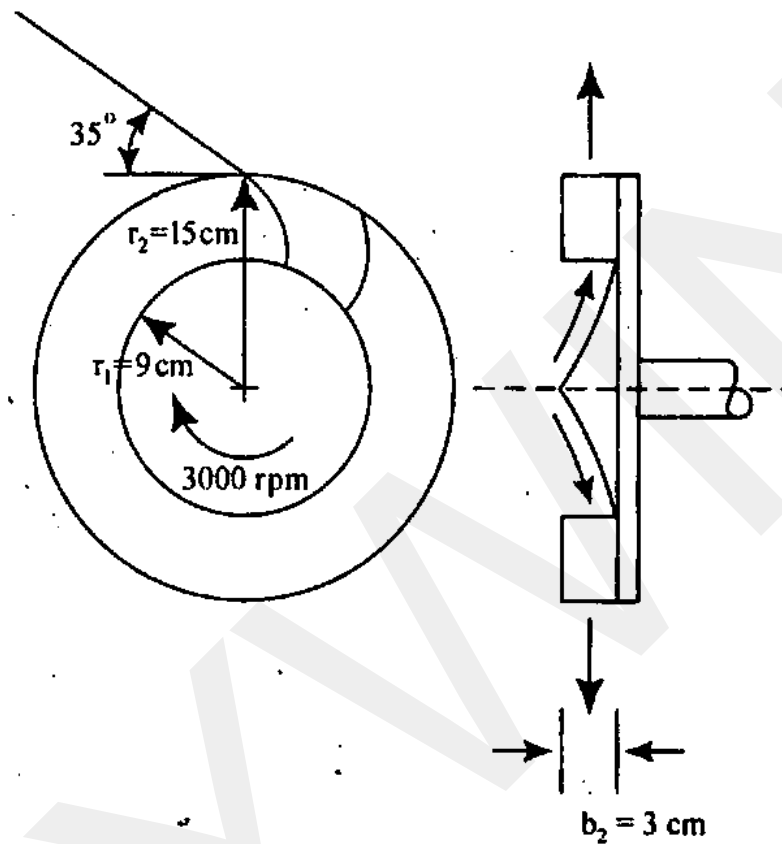

The front and side views of a centrifugal pump impeller rotating at 3000 rpm are as shown in the above figure. If the pump delivers 200 litres of water per second and the blade exit angle is 35° from the tangential direction, determine the power requirement associated with the flow. The flow entering the impeller blade row is essentially radial as viewed from a stationary frame. The inner and outer radii are respectively 9 cm and 15 cm and the width is constant at 3 cm as shown. 10

(e)

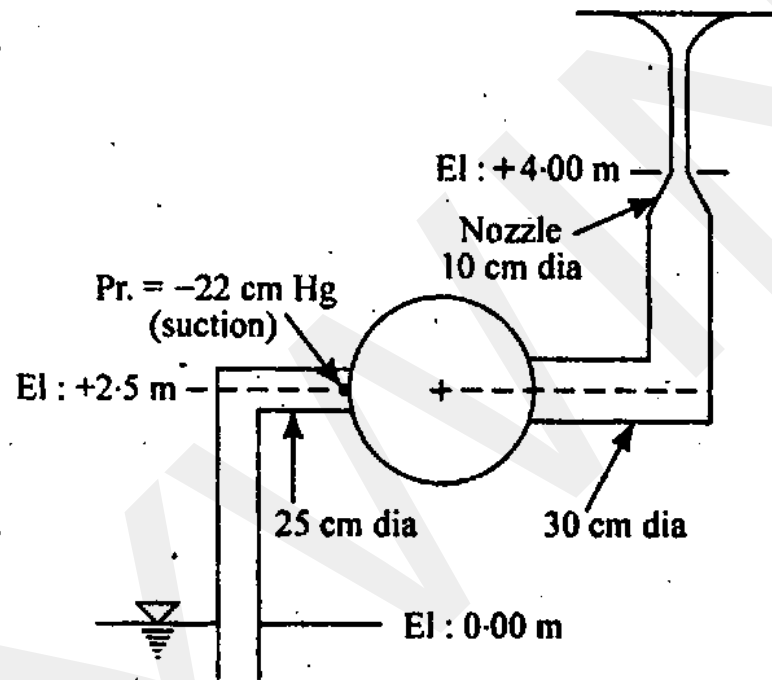

A pump is 2.5 m above the water level in a sump as shown in the above figure and has a pressure of -22 cm of Mercury at the suction side. The suction pipe is of 25 cm diameter and the delivery pipe is a short 30 cm diameter pipe ending in a nozzle of 10 cm diameter. If the nozzle is directed vertically upwards with its tip at an elevation of 4.0 m above the sump water level, determine

- (i) the discharge
- (ii) power input to the flow by the pump and
- (iii) the elevation up to which the jet would reach above the sump water level.

Assume ideal flow and neglect all losses in the system.

Take $\rho_{\text{water}} = 1000 \text{ kg/m}^3$. 10

2. (a) A masonry dam 6 m high has 1.0 m top width and 4.0 m base width. It retains water on its vertical face for its total height. Determine the stresses that develop at its base and check the section for its stability. Assume the density of the masonry be 24 kN/m^3 safe bearing capacity of the soil as 150 kN/m^2 , unit weight of water as 10 kN/m^3 and the coefficient of friction between masonry and the foundation bed as 0.6. Factor of safety required against sliding is 1.5. 20

- (b) Two wheel loads of 100 kN and 50 kN magnitude spaced at 1.0 m apart, move on a simply supported girder of 8 m span from left to right with 50 kN load leading. Find the maximum positive shear force and the bending moment at a section 3 m from the left support. Use influence method. 20

3. (a)

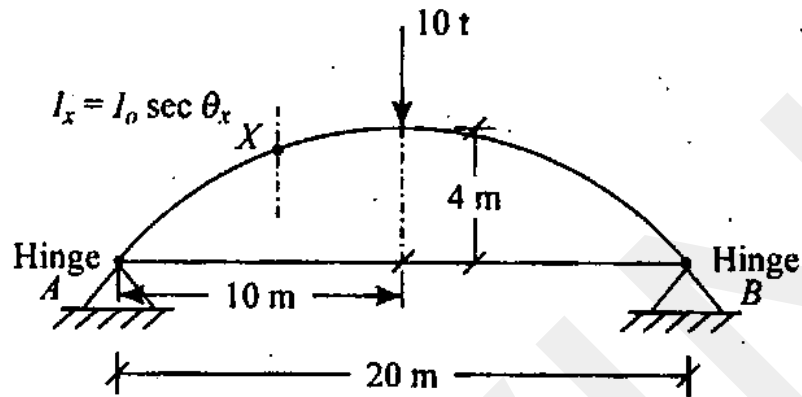

Find the horizontal thrust at B in the two hinged arch as shown in the above figure. Assume that $I_x = I_0 \sec \theta_x$ where I_x and θ_x are respectively the sectional moment of inertia and the slope of the tangent at X , and I_0 is a constant. Neglect all effects except bending. 20

- (b) A horizontal jet of water emerging from an 85 mm nozzle with a uniform speed, 3.0 m/s strikes a vane, and is turned through an angle θ . Neglecting gravity and viscous effects, obtain expressions for the components of anchoring force in terms of θ , that are required to hold the vane stationary. Using the expressions so obtained, obtain the anchoring force components for $\theta = 90^\circ$ and 180° , clearly indicating how the magnitude and direction of these forces change with the angle of diversion. The resultant forces need not be computed for these cases. 10

- (c) A 2.5 m diameter tank of height 2.5 m is closed at the top and contains a liquid of specific gravity 0.75, up to a height of 2.0 m. If the space above the liquid is under a pressure of -3 kPa (suction), calculate (a) force acting on the bottom of the tank when it is accelerated vertically upwards at 0.5 times g and (b) the acceleration required for maintaining zero absolute pressure at the tank bottom. Take atmospheric pressure as 100 kN/m² and water density as 1000 kg/m³. 10
4. (a) Determine the speed and torque required to drive an agitator of 675 mm diameter rotating in air if a similar agitator of diameter 225 mm rotating at 23 rev/s in water requires a torque of 1.1 N-m. Given $\rho_{\text{air}} = 1.23$ kg/m³, $\rho_{\text{water}} = 1000$ kg/m³, $\mu_{\text{air}} = 1.86 \times 10^{-5}$ Pa-s, $\mu_{\text{water}} = 1.01 \times 10^{-3}$ Pa-s. Obtain your result after arriving at the relevant group of dimensionless terms and the corresponding similarity law, considering that the power required is a function of the speed, diameter of agitator, the fluid and viscosity of the fluid in which the agitator rotates. 20
- (b) (i) Water flows in a rectangular channel of width 10 m. If the Manning's coefficient $n = 0.025$ obtain a relationship between the bed slope (S_o) and the depth of flow (y) as a function of Froude number (F_r). Determine therefrom the bed slope of the channel required to maintain critical conditions corresponding to a depth of 1 m. 8

- (ii) Water flows in a channel of uniform width at a rate of $0.534 \text{ m}^2/\text{s}$ (per metre width). The depth of flow at a particular section in this channel is 70 cm and, beyond this section, the bed is raised by 15 cm. Determine the possible depths of flow at the elevated part of the channel. Identify the actual depth out of the possible values. Justify your answer through proper reasoning. 12

Section – B

5. Attempt any *four* of the following : 10×4=40

- (a) Design a suitable fillet weld to connect a tie bar $60 \text{ mm} \times 8 \text{ mm}$ to a 12 mm thick gusset plate. The permissible stresses in the tie bar and fillet weld are 150 MPa and 108 MPa respectively. 10
- (b) A 5 m long simply supported beam carries a superimposed load of 20 kN/m. Design the mid span section of the beam if its effective depth is kept constant at 500 mm, using Limit State method. Neglect the weight (self) of the beam. Use M15 concrete and Fe 415 grade steel. 10
- (c) (i) Enumerate various types of losses in Pretensioning and Post-tensioning. 5

- (ii) A dry sandy soil is placed inside a $10\text{ cm} \times 10\text{ cm} \times 10\text{ cm}$ cube in its loosest possible state to occupy the entire volume. Its weight is 1550 g . Then, the soil is compacted by vibration to occupy the cube in its densest possible state, when it settled by 2 cm . A natural deposit of the same soil has a water content of 12% and a moist density of 1.9 g/cc . Compute the density index (relative density) of the soil in its natural state. 5

(d)

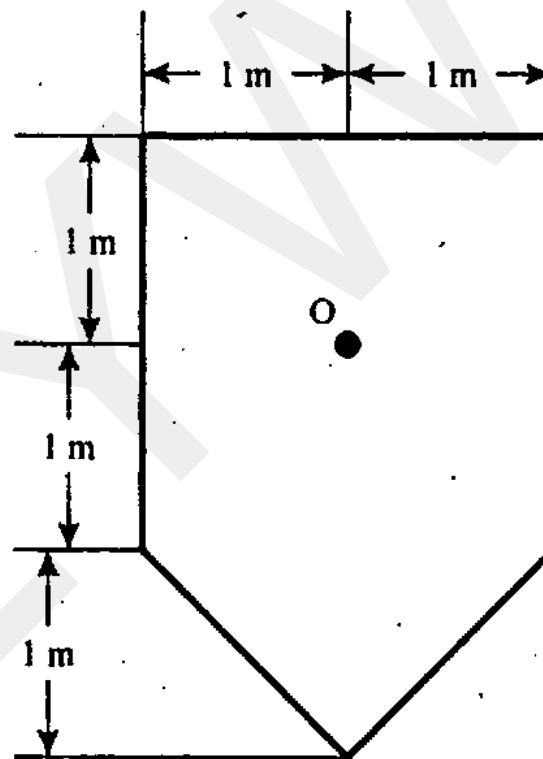

Compute the vertical stress on a horizontal plane situated at a depth of 2 m below the point O in the above figure. The area is loaded uniformly to an intensity of 300 kN/m^2 . 10

- (e) A 5 m high retaining wall with a smooth and vertical back retains a soil having a unit weight of 19.18 kN/m^3 , undrained cohesion of 16.75 kN/m^2 and angle of internal friction of 0° . Compute the depth of the tension cracks. What is the resultant thrust on the back of the wall (i) before the formation of tension cracks (ii) after the formation of tension cracks ? 10

6. (a) (i) Distinguish between Deck type and Through type of Steel Truss bridges. Illustrate with simple sketches. 6

- (ii) A simply supported steel beam of 7.0 m span is uniformly loaded with 40 kN/m . The sections available are MB 300, MB 350 and MB 400 and for a limiting deflection of $\frac{1}{325}$ of span, the span/depth ratio is 17.9.

Design the beam, taking σ_y for steel as 250 MPa . Z values for M 300, MB 350 and MB 400 are 573.6 cm^3 , 778.9 cm^3 and 1022.9 cm^3 respectively. 14

- (b) A reinforced concrete short column of 480 mm diameter is reinforced with 6 nos. 20 mm dia. HYSD bars of grade Fe 415 and 8 mm dia. Helix with 75 mm pitch. Calculate the maximum load carrying capacity of the column, if concrete used is M 25. Consider nominal cover of 40 mm to helix. 20

7. (a) Design an isolated footing for an R. C. column of 300 mm × 300 mm size carrying an axial load of 320 kN. The safe bearing capacity of soil is 150 kN/m². Take M 20 concrete and Fe 415 grade steel. Adopt working stress method. Allowable shear stress data are given below : 20

P_t	τ_c (N/mm ²)
0.25	0.22
0.50	0.30
0.75	0.35
1.00	0.39
1.25	0.42
1.50	0.45

- (b) Results of two drained triaxial tests on a saturated clay are as follows :

	Sample 1	Sample 2
Cell pressure (kN/m ²)	80	160
Deviator stress at failure (kN/m ²)	141.5	223.5

Compute the effective cohesion and effective angle of internal friction. 5

- (c) What are the corrections that need to be applied to the standard penetration resistance (N) value obtained in a fine sandy soil situated below the water table? Why are the corrections necessary? 5
- (d) A 2 m-wide strip footing is placed 1 m below the ground surface of a clay having the following properties :
- (i) $c_u = 80 \text{ kN/m}^2$; $\phi_u = 0^\circ$
 - (ii) $c' = 0$; $\phi' = 30^\circ$

The unit weight of the soil above the water table is 16 kN/m^3 and that below the water table is 20 kN/m^3 .

Calculate the net safe bearing capacity of the footing, adopting a factor of safety of 2 for the conditions of the water table being at the foundation level and water table being at the ground level, assuming that

- (i) the load is applied at once so that the pore water cannot escape.
- (ii) the load is applied gradually, giving enough time for the dissipation of the pore water pressure.

Given,

$$\text{For } \phi = 0^\circ; N_c = 5.7; N_q = 1.0; N_\gamma = 0.0$$

$$\phi = 30^\circ; N_c = 37.2; N_q = 22.5; N_\gamma = 19.7$$

10

8. (a) An excavation has to be made in a 10 m deep clay stratum underlain by sand. In a trial bore hole made close to the excavation, the ground water was found to rise to an elevation of 3 m below the ground level. What is the safe depth of excavation without its bottom becoming unstable due to the uplift pressure of the ground water? If the excavation has to be safely made up to a depth of 7 m, what is the depth to which the water table has to be lowered in the vicinity of the excavation? Specific gravity of the clay particles is 2.7. Take void ratio of the clay as 0.7. 5

(b) A clay deposit is 12 m thick and draining on both faces. The coefficient of consolidation of the clay was found to be $8.64 \times 10^{-4} \text{ m}^2/\text{day}$. The ultimate settlement of the clay was estimated to be 1.2 m. How long would it take for settlements of 400 mm and 800 mm to occur? How much settlement would occur in 10 years and 50 years? 20

(c) A $3.3 \text{ m} \times 2.2 \text{ m}$ group consists of 9 m long piles. It carries a load of 1500 kN. The piles penetrate a sand layer (bulk unit weight = 16 kN/m^3), 1 m thick, and rest in a normally consolidated clay having a saturated unit

weight of 19 kN/m^3 , specific gravity of 2.7 and liquid limit of 50. Clay extends to a depth of 12 m below the top of the sand layer. Ground water is at a depth of 1 m below the ground surface. Bulk unit weight of sand is 16 kN/m^3 . Compute the settlement in the clay, if the pile cap rests on the top of sand. Use 2 : 1 stress distribution to estimate the average increase of stress in the clay layer. 15