

Engg. Services Exam, 2011

Sl. No. 22001

D-RSR-L-PRA

CIVIL ENGINEERING**Paper—I**

(Conventional)

Time Allowed : Three Hours

Maximum Marks : 200

INSTRUCTIONS

Candidates should attempt any FIVE questions.

The number of marks carried by each subdivision of a question is indicated at the end of the subdivision.

The total number of marks for each question will be 40.

Answers must be written only in ENGLISH.

Notations used are standard and will have their usual meanings, unless otherwise indicated.

Assume suitable data, if found necessary, and indicate them clearly. Newton may be converted to kgf using the relation 1 kilonewton (1 kN) = 100 kgf, if found necessary.

1. (a) What are the different types of Portland cement as per Indian code of practice? Discuss any two. 10
- (b) Explain in detail the ultrasonic pulse velocity method of non-destructive testing of concrete. 5

/68

[P.T.O.

- (c) Discuss how consistency of cement is determined. 5
- (d) Discuss the types of mortar which can be used for the following types of masonry work with suggested proportions : 5
- (i) Masonry in foundation and plinth
 - (ii) Masonry in superstructure
 - (iii) Plastering work
 - (iv) Pointing
- (e) Discuss the factors affecting the strength of timber. 5
- (f) Briefly describe the various defects in bricks. 5
- (g) Briefly explain the processes involved in the manufacture of bricks in order. 5
2. (a) A compound bar consists of a circular rod of steel of diameter 25 mm, rigidly fitted into a copper tube of internal diameter 25 mm and thickness 2.5 mm. If the bar is subjected to an axial load of 100 kN, find the stresses developed in the two materials. Given, $E_s = 2 \times 10^5 \text{ N/mm}^2$ and $E_c = 1.2 \times 10^5 \text{ N/mm}^2$. 10

- (b) A circular log of timber has diameter D . Determine the dimension of the strongest rectangular section, one can cut from this log.

10

- (c) Draw the bending moment and shear force diagrams for overhanging beam shown in the figure below. Indicate the significant values including the point of contraflexure.

10

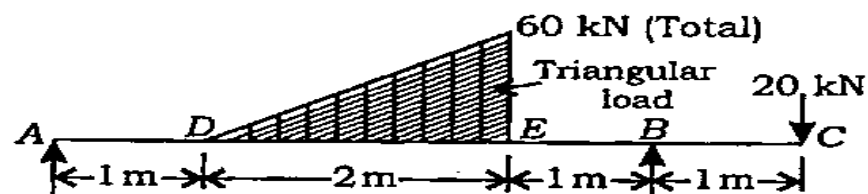

- (d) A solid shaft transmits 250 kW at 100 r.p.m. If the shear stress is not to exceed 75 N/mm^2 , what should be the diameter of the shaft?

If this shaft is to be replaced by a hollow shaft whose internal diameter shall be 0.6 times the outer diameter, determine the size and percentage saving in weight, maximum stresses being the same.

10

3. (a) Analyse the truss shown in the figure below and list out the forces in the members.

14

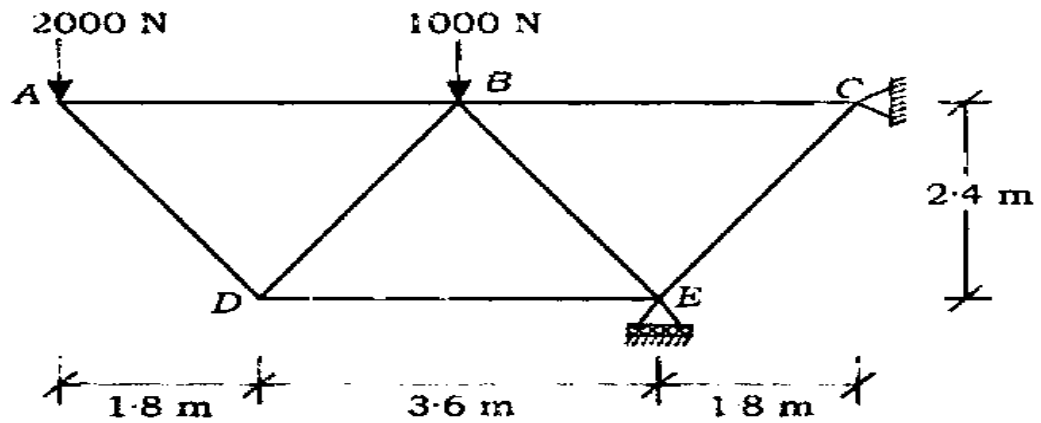

- (b) Three members of the truss shown in the figure below have been cut either too long (+ve) or too short (-ve) as per details given below. Calculate the vertical displacement of joint D due to discrepancies in the length of these members by unit load method.

$$\delta_{AB} = -3 \text{ mm}; \quad \delta_{EC} = 2 \text{ mm}; \quad \delta_{EF} = 4 \text{ mm}$$

All members have the same area of cross-section.

10

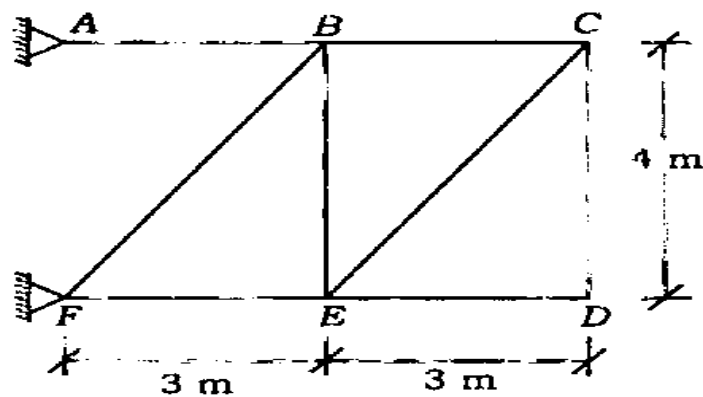

- (c) A beam AB of 6 m span carries a distributed load of varying intensity as shown in the figure below. Calculate the deflection at the centre of the beam.

Load intensity at support $B = 1.2 \text{ kN/m}$,
 $EI = 420 \times 10^6 \text{ N-mm}^2$.

16

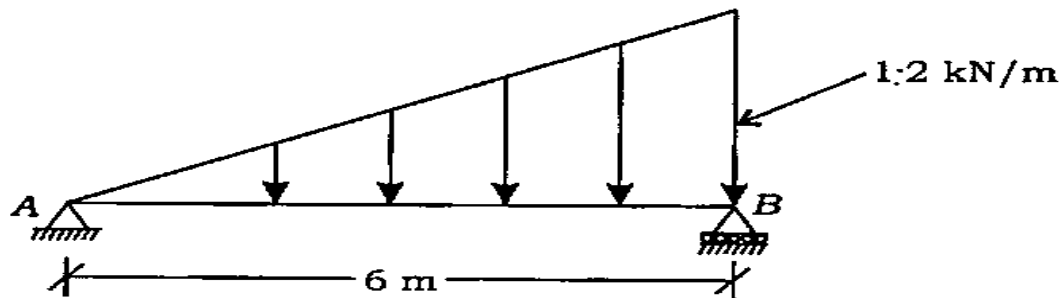

4. (a) Analyse the continuous beam shown in the figure below by slope deflection method. Support B settles down by 5 mm.

$E = 2 \times 10^5 \text{ N/mm}^2$, $I = 36 \times 10^6 \text{ mm}^4$

16

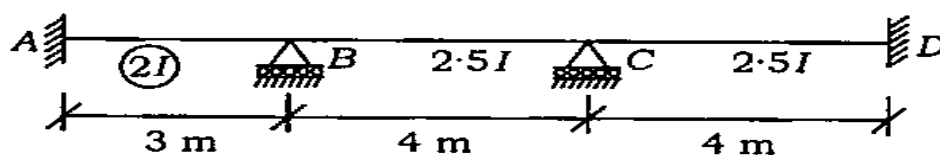

- (b) (i) Distinguish between yield moment and plastic moment capacity of a section.

2

- (ii) Determine the shape factor from first principles for a triangular section of base width b and height h .

12

- (c) Develop the stiffness matrix for the frame shown in the figure below with coordinates 1 and 2 indicated. 10

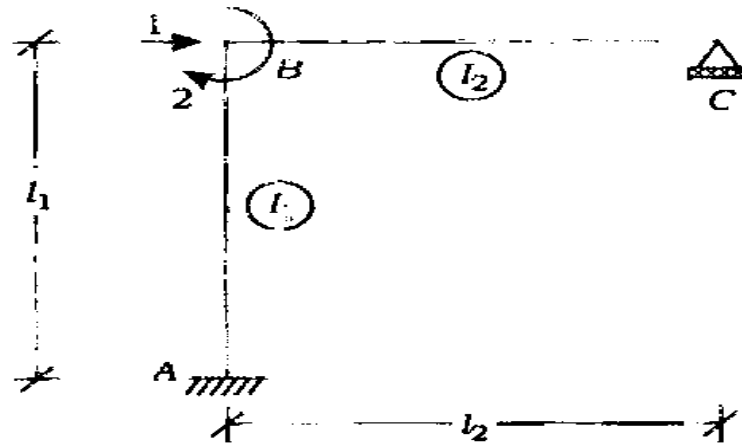

5. (a) (i) List out five merits and three demerits of welded joints. 4
- (ii) Determine the size of the fillet weld required to join a bracket plate with the flange of a column section shown in the figure below. Permissible stress in weld = 108 MPa. 10

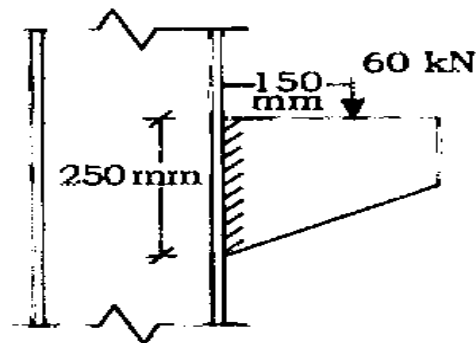

- (b) A beam MB 600 @ 123 kgf is supported over an effective span of 9 m. Two floor joists transmit floor loads at a distance of 1.5 m on either side of the midspan. Determine the safe load which the two floor joists can transmit on the beam if the beam is effectively restrained laterally by the floor joists.

Properties of MB 600 @ 123 kgf are :

Overall depth $D = 600$ mm

Width of flange $b = 210$ mm

Depth of web $d_1 = 558.4$ mm

Mean thickness of flange $t_f = 20.8$ mm

Thickness of web $t_w = 12$ mm

Radius of gyration about yy -axis

$$r_y = 41.2 \text{ mm}$$

Modulus of section about xx -axis

$$Z_x = 3060 \times 10^3 \text{ mm}^3$$

Modulus of section about yy -axis

$$Z_y = 252 \times 10^3 \text{ mm}^3$$

Maximum permissible bending stress σ_{bc} (N/mm^2) for $t_f/t_w < 2$ and $d_1/t_w < 85$ is given in the table below as a function of slenderness ratio (l/r) and D/t_f :

12

$D/t_f \backslash l/r$	20	25	30	35	40
60	151	150	149	149	149
65	148	147	146	146	145
70	146	144	143	142	142
75	143	141	140	139	138
80	140	138	136	135	134

- (c) Design an unequal angle section to serve as a tie member of 1.6 m length in a roof truss. It has to carry an axial load of 118 kN. The gusset plate is connected to the longer leg of the angle. Also design the fillet weld.

Permissible stress in weld

$$= 108 \text{ N/mm}^2$$

Permissible stress in axial tension

$$= 150 \text{ N/mm}^2$$

Thickness (t), sectional area (A), weight/m run (w), distance of centres of gravity along x and y -axis (c_x and c_y), and maximum and minimum radius of gyration r_{max} and r_{min} are given for some angles for design.

14

Angle	t	A	w	c_x	c_y	r_{max}	r_{min}
80 × 50	6	746	5.9	26.4	11.6	26.9	10.7
	8	978	7.7	27.3	12.4	26.6	10.6
	10	1202	9.4	28.1	13.2	26.3	10.6
90 × 60	6	865	6.8	28.7	13.9	30.7	12.8
	8	1137	8.9	29.6	14.8	30.4	12.7
	10	1401	11.0	30.4	15.5	30.1	12.7

6. (a) Design a circular column with helical reinforcement subjected to a working load of 1500 kN. Diameter of the column is 450 mm. The column has unsupported length of 3.5 m and is effectively held in position at both ends but not restrained against rotation. Use limit state design method. Use M-25 concrete and HYSD Fe-415 steel. 20
- (b) What are the various methods of pre-stressing? Also discuss the most widely used methods of pre-tensioning and post-tensioning of concrete elements. 10
- (c) Design a constant thickness footing for a reinforced concrete column of 300 mm × 300 mm. The column is carrying an axial working load of 600 kN. The BC of soil is 200 kN/m². Use M-25 concrete and HYSD Fe-415 bars. Use limit state design method. 10

$\frac{100 A_{st}}{bd}$	0.15	0.25	0.50	0.75	1.0
τ_c (N / mm ²)	0.19	0.36	0.49	0.57	0.64

7. (a) Explain the various methods of comparison of civil engineering project alternatives. 10

- (b) (i) Discuss and differentiate line organisation and staff organisation.
- (ii) Differentiate resource levelling and resource smoothing.
- (c) The data for planning a project by network technique is given below :

10

Activity	Duration (in weeks)	Activities immediately	
		Preceding	Following
A	4	—	B, C
B	4	A	D, F
C	6	A	E, G
D	3	B	E, G
E	5	C, D	H, I
F	6	B	I
G	5	C, D	I
H	7	E	—
I	4	E, F, G	—

For the above data, answer the following :

- (i) Draw the CPM diagram.
- (ii) Prepare a CPM schedule and calculate F_T , F_F and F_{IN} .
- (iii) State the critical path.
- (iv) Indicate the project duration.

10

- (d) (i) Describe the method of conveying materials with belt conveyors. List the components. State the advantages. 5
- (ii) List the different types of equipments used for excavation work. 5

★ ★ ★

